

AL-MCP2210 - USB to SPI Bridge

SCHEMATIC DIAGRAM REVISION 1.0

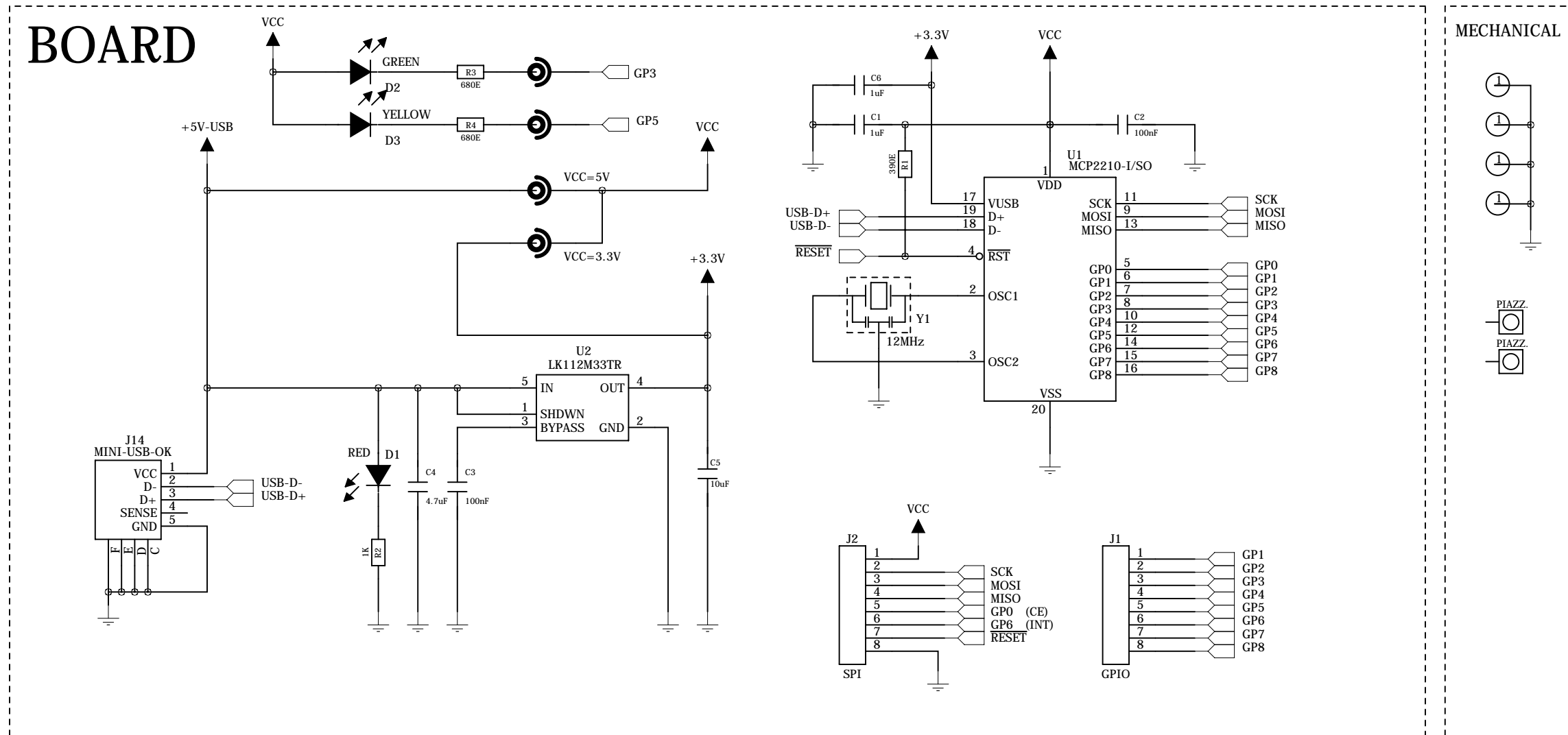

For more information: www.artekit.eu

NOTE: This board was designed and produced in Italy

Design Disclaimer

Artekit Italy ("ARTEKIT") provides this design as a service to our customers. Artekit has made a good faith attempt to build for the specifications provided or needed by the customer. Artekit provides this product "as is" and without "recourse" and MAKES NO WARRANTY, EXPRESSED, IMPLIED OR OTHERWISE, INCLUDING ANY WARRANTY OF MERCHANTABILITY AND FITNESS FOR A PARTICULAR PURPOSE.



DRAWN: RHM DATED: 04/08/2014
CHECKED: IBM
RELEASED: RHM/IBM DATED: 04/08/2014

COMPANY: ARTEKIT ITALY		REV:
TITLE: AK-MCP2210		
SIZE: B	USB to SPI Bridge	SHEET: 1 OF 1
SCALE: 1/1		